

REV	ECO #	BY	DATE	CHK	REVISION
A	7193	BH	6.15.00	JEF	RELEASE

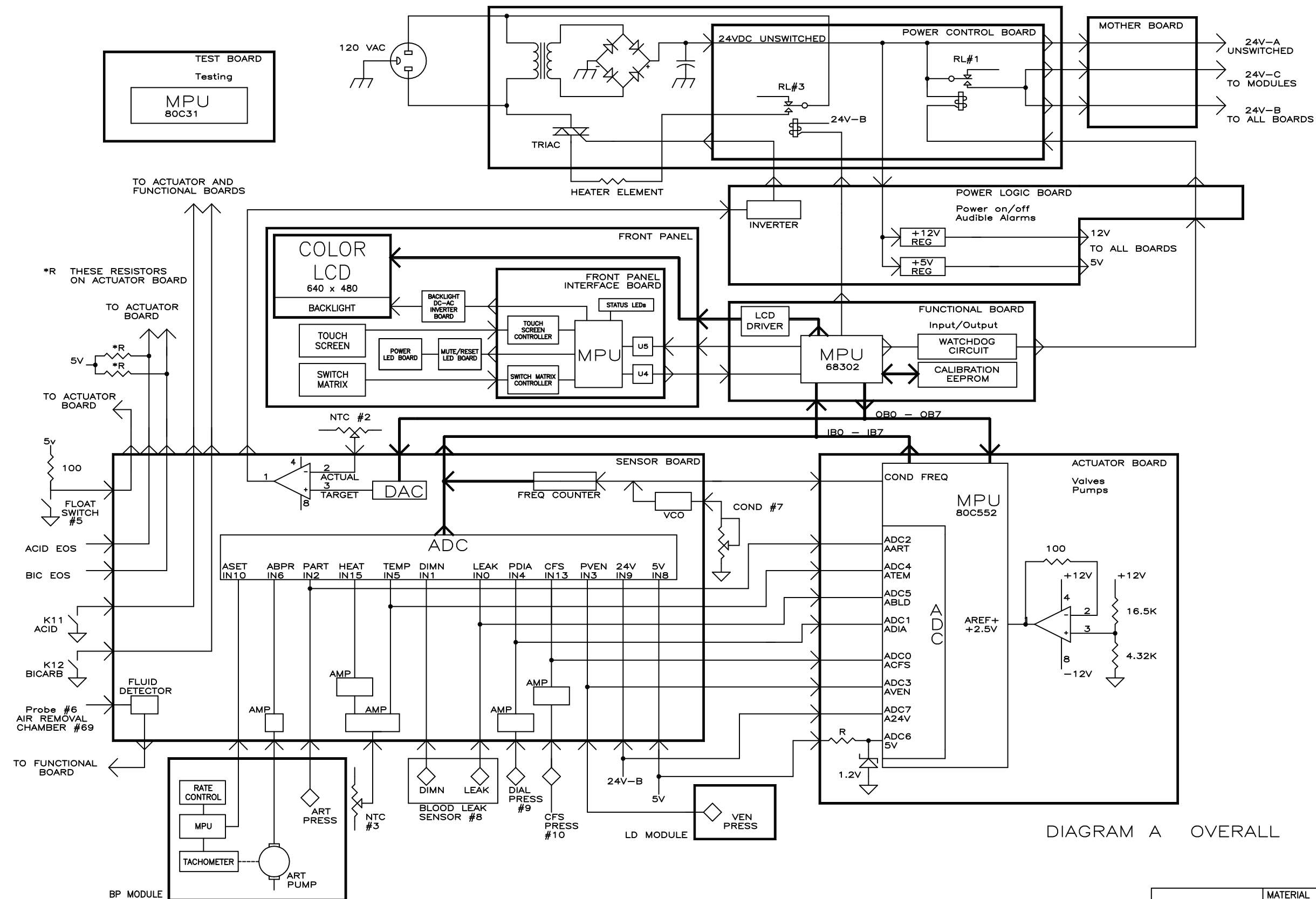

DIAGRAM A OVERALL

This document is the property of Fresenius Medical Care, Inc. and contains confidential and trade secret information of Fresenius Medical Care. This document may only be transferred from the custody or control of Fresenius Medical Care only as authorized by Fresenius Medical Care and then only by way of loan for limited purposes. It must not be reproduced in whole or in part and must be returned to Fresenius Medical Care upon request and in all events upon completion of the purpose of the loan. Neither this document nor the information it contains may be used or disclosed to persons not having a need for such use or disclosure consistent with the purpose of the loan, without prior written consent of Fresenius Medical Care.

DATE		NAME		MATERIAL	
DRAWN	3.25.99	B.	LEPARD	2008K ELECTRONIC BLOCK DIAGRAM	
				290174	
				REV. A SHEET 1 OF 11	
				O:\ACAD\2\290174-1.DWG	



REV	ECO #	BY	DATE	CHK	REVISION
A	7193	BH	6.15.00	JEF	RELEASE

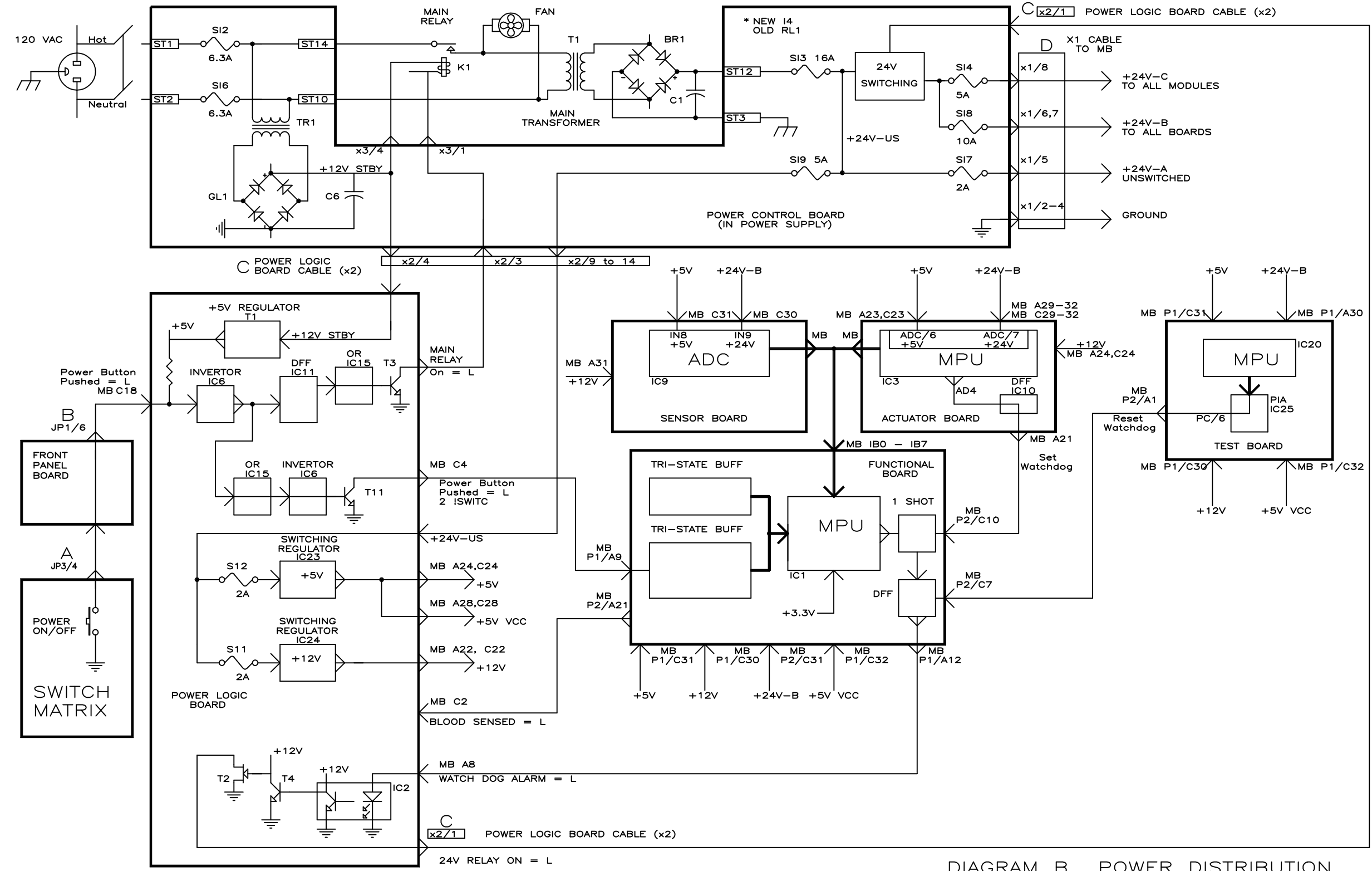

DIAGRAM B POWER DISTRIBUTION

This document is the property of Fresenius Medical Care, Inc. and contains confidential and trade secret information of Fresenius Medical Care. This document may only be transferred from the custody or control of Fresenius Medical Care only as authorized by Fresenius Medical Care and then only by way of loan for limited purposes. It must not be reproduced in whole or in part and must be returned to Fresenius Medical Care upon request and in all events upon completion of the purpose of the loan. Neither this document nor the information it contains may be used or disclosed to persons not having a need for such use or disclosure consistent with the purpose of the loan, without prior written consent of Fresenius Medical Care.

DATE		NAME		MATERIAL	
DRAWN	3.25.99	B.	LEPARD	2008K ELECTRONIC BLOCK DIAGRAM	
				290174	
				0:\ACAD\2\290174-2.DWG	
				SCALE	NONE
				REV. A	SHEET 2 OF 11



REV	ECO #	BY	DATE	CHK	REVISION
A	7193	BH	6.15.00	JEF	RELEASE

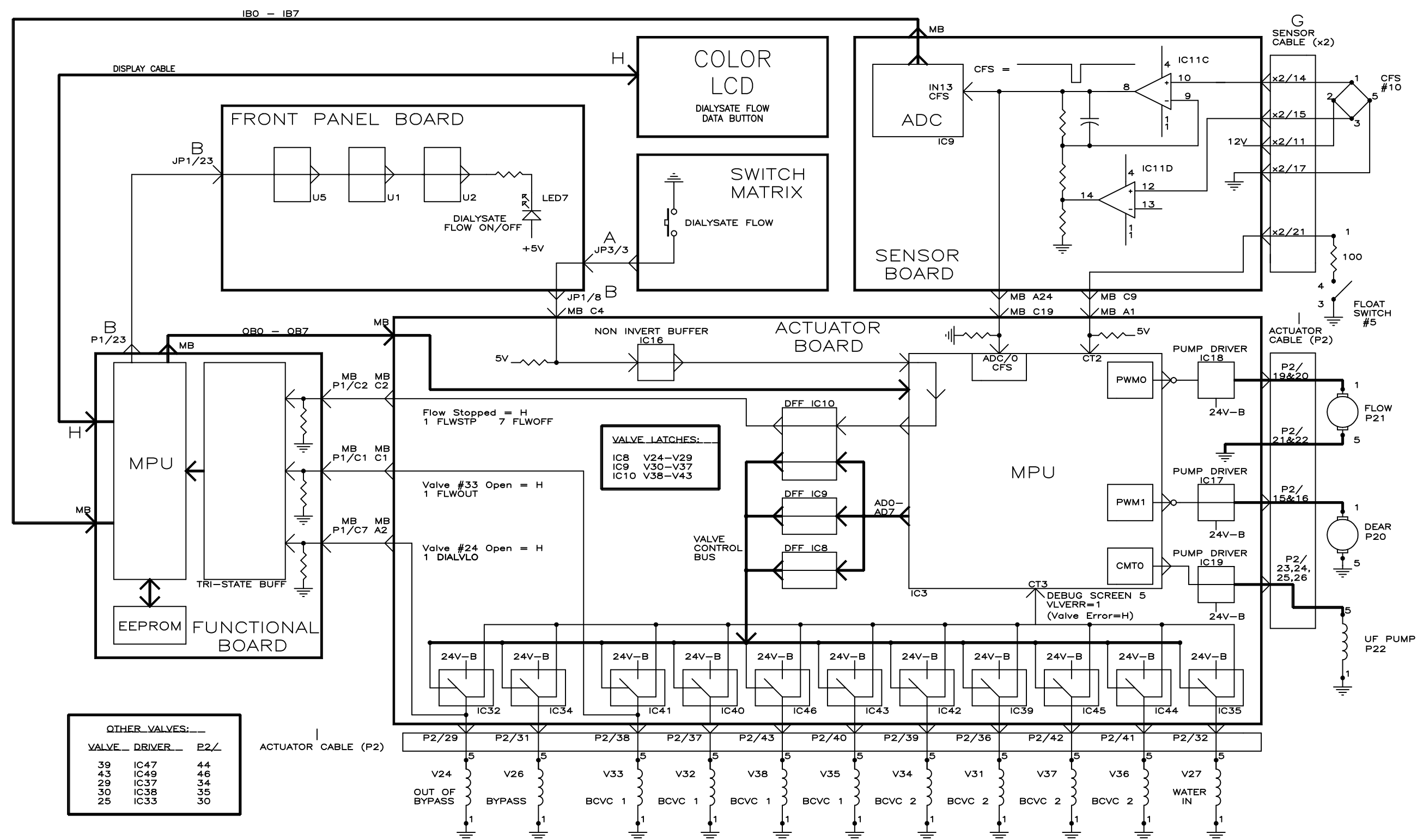

**OTHER VALVES:---**

VALVE	DRIVER	P2/
39	IC47	44
43	IC49	46
29	IC37	34
30	IC38	35
25	IC33	30

DIAGRAM C FLOW

This document is the property of Fresenius Medical Care, Inc. and contains confidential and trade secret information of Fresenius Medical Care. This document may only be transferred from the custody or control of Fresenius Medical Care only as authorized by Fresenius Medical Care and then only by way of loan for limited purposes. It must not be reproduced in whole or in part and must be returned to Fresenius Medical Care upon request and in all events upon completion of the purpose of the loan. Neither this document nor the information it contains may be used or disclosed to persons not having a need for such use or disclosure consistent with the purpose of the loan, without prior written consent of Fresenius Medical Care.

DATE		NAME		MATERIAL	
DRAWN	3.25.99	B.	LEPARD	2008K ELECTRONIC BLOCK DIAGRAM	
				290174	
				O:\ACAD\2\290174-3.DWG	
				SCALE	NONE
				REV. A	SHEET 3 OF 11



REV	ECO #	BY	DATE	CHK	REVISION
A	7193	BH	6.15.00	JEF	RELEASE

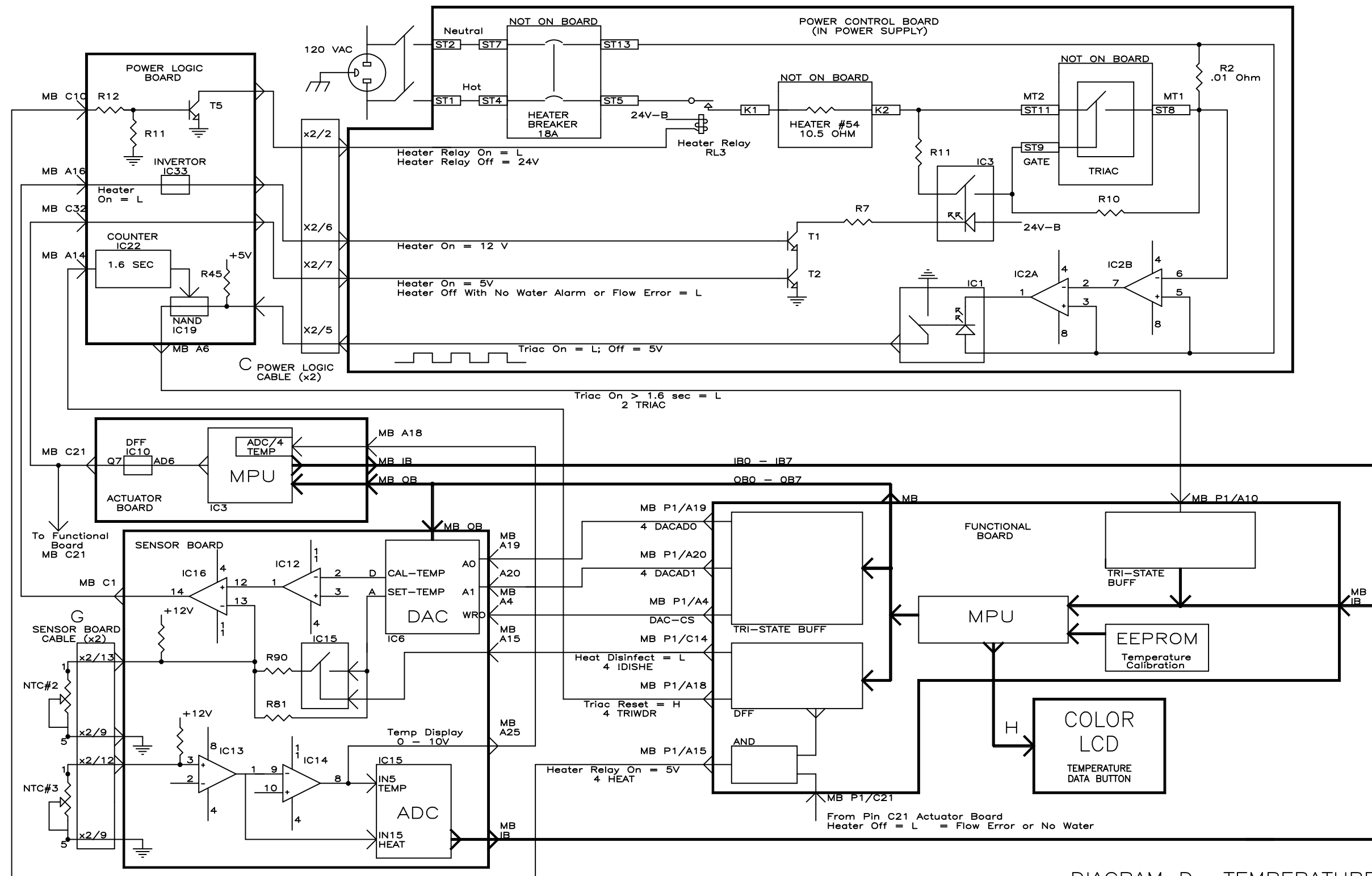

DIAGRAM D TEMPERATURE

This document is the property of Fresenius Medical Care, Inc. and contains confidential and trade secret information of Fresenius Medical Care. This document may only be transferred from the custody or control of Fresenius Medical Care only as authorized by Fresenius Medical Care and then only by way of loan for limited purposes. It must not be reproduced in whole or in part and must be returned to Fresenius Medical Care upon request and in all events upon completion of the purpose of the loan. Neither this document nor the information it contains may be used or disclosed to persons not having a need for such use or disclosure consistent with the purpose of the loan, without prior written consent of Fresenius Medical Care.

DATE		NAME		MATERIAL	
DRAWN	3.25.99	B.	LEPARD	2008K ELECTRONIC BLOCK DIAGRAM	
				290174	
				O:\ACAD\2\290174-4.DWG	
				SCALE	NONE
				REV.	A
				SHEET	4 OF 11



REV	ECO #	BY	DATE	CHK	REVISION
A	7193	BH	6.15.00	JEF	RELEASE

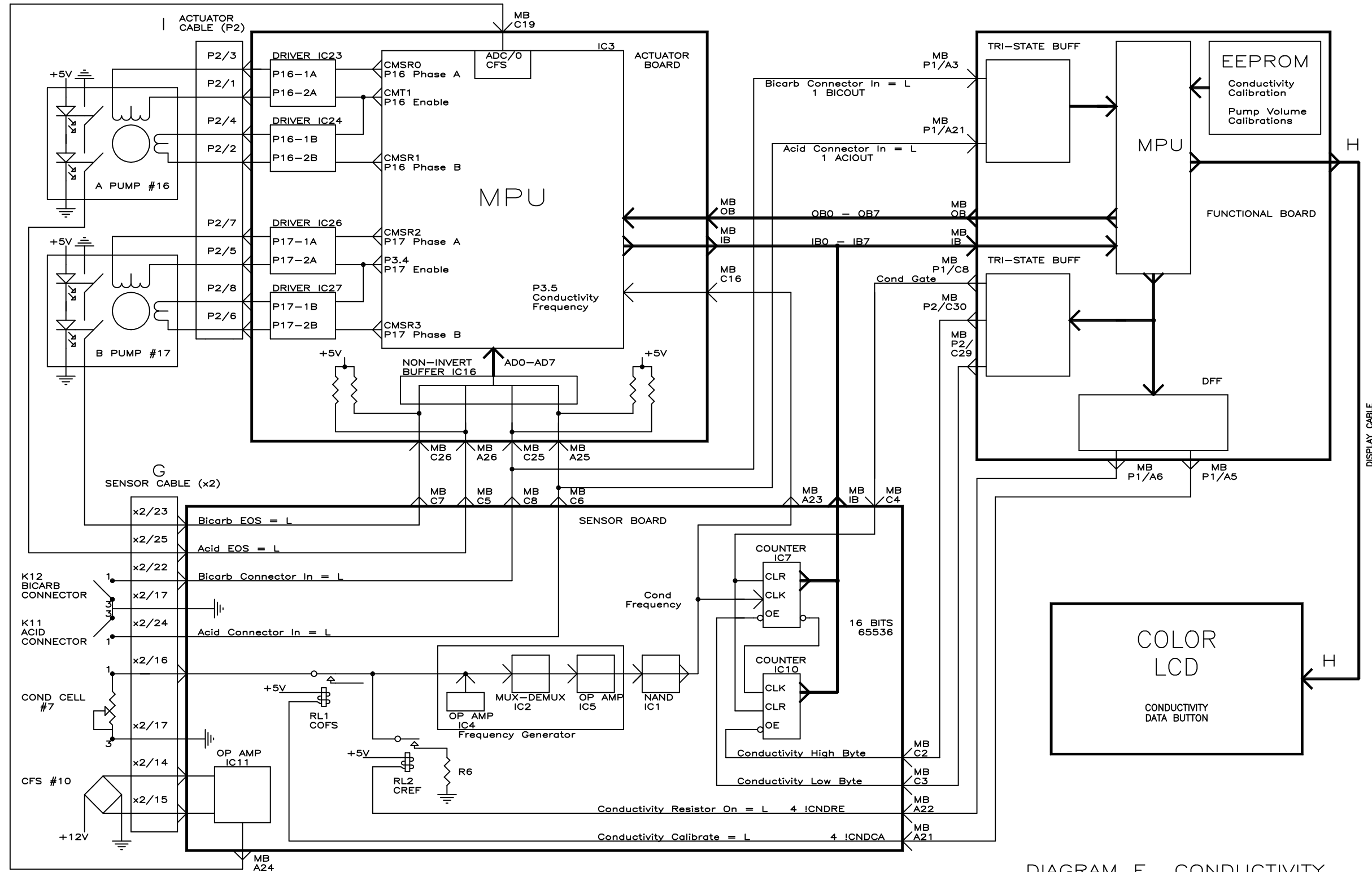

DIAGRAM E CONDUCTIVITY

This document is the property of Fresenius Medical Care, Inc. and contains confidential and trade secret information of Fresenius Medical Care. This document may only be transferred from the custody or control of Fresenius Medical Care only as authorized by Fresenius Medical Care and then only by way of loan for limited purposes. It must not be reproduced in whole or in part and must be returned to Fresenius Medical Care upon request and in all events upon completion of the purpose of the loan. Neither this document nor the information it contains may be used or disclosed to persons not having a need for such use or disclosure consistent with the purpose of the loan, without prior written consent of Fresenius Medical Care.

DATE		NAME		MATERIAL	
DRWN	3.25.99	B.	LEPARD	2008K ELECTRONIC BLOCK DIAGRAM	
				SCALE NONE	
				290174	
				REV. A SHEET 5 OF 11	
				0:\ACAD\2\290174-5.DWG	

REV	ECO #	BY	DATE	CHK	REVISION
A	7193	BH	6.15.00	JEF	RELEASE

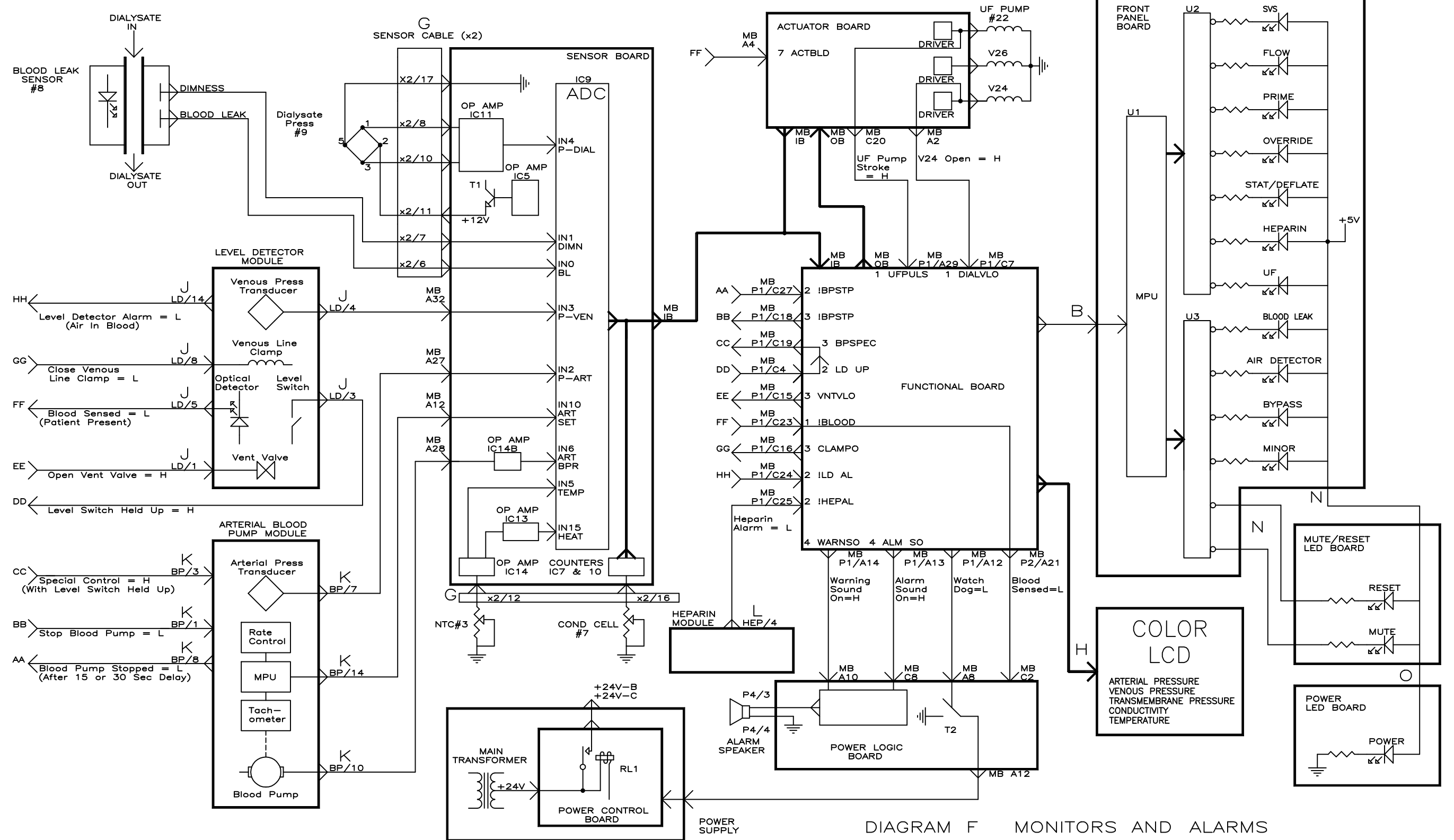

DIAGRAM F MONITORS AND ALARMS

This document is the property of Fresenius Medical Care, Inc. and contains confidential and trade secret information of Fresenius Medical Care. This document may only be transferred from the custody or control of Fresenius Medical Care only as authorized by Fresenius Medical Care and then only by way of loan for limited purposes. It must not be reproduced in whole or in part and must be returned to Fresenius Medical Care upon request and in all events upon completion of the purpose of the loan. Neither this document nor the information it contains may be used or disclosed to persons not having a need for such use or disclosure consistent with the purpose of the loan, without prior written consent of Fresenius Medical Care.

DATE		NAME		MATERIAL	
DRAWN 3.25.99		B. LEPPARD		2008K ELECTRONIC BLOCK DIAGRAM	
				SCALE NONE	
				REV. A SHEET 6 OF 11	
				290174 O:\ACAD\2\290174-6.DWG	

REV	ECO #	BY	DATE	CHK	REVISION
A	7193	BH	6.15.00	JEF	RELEASE

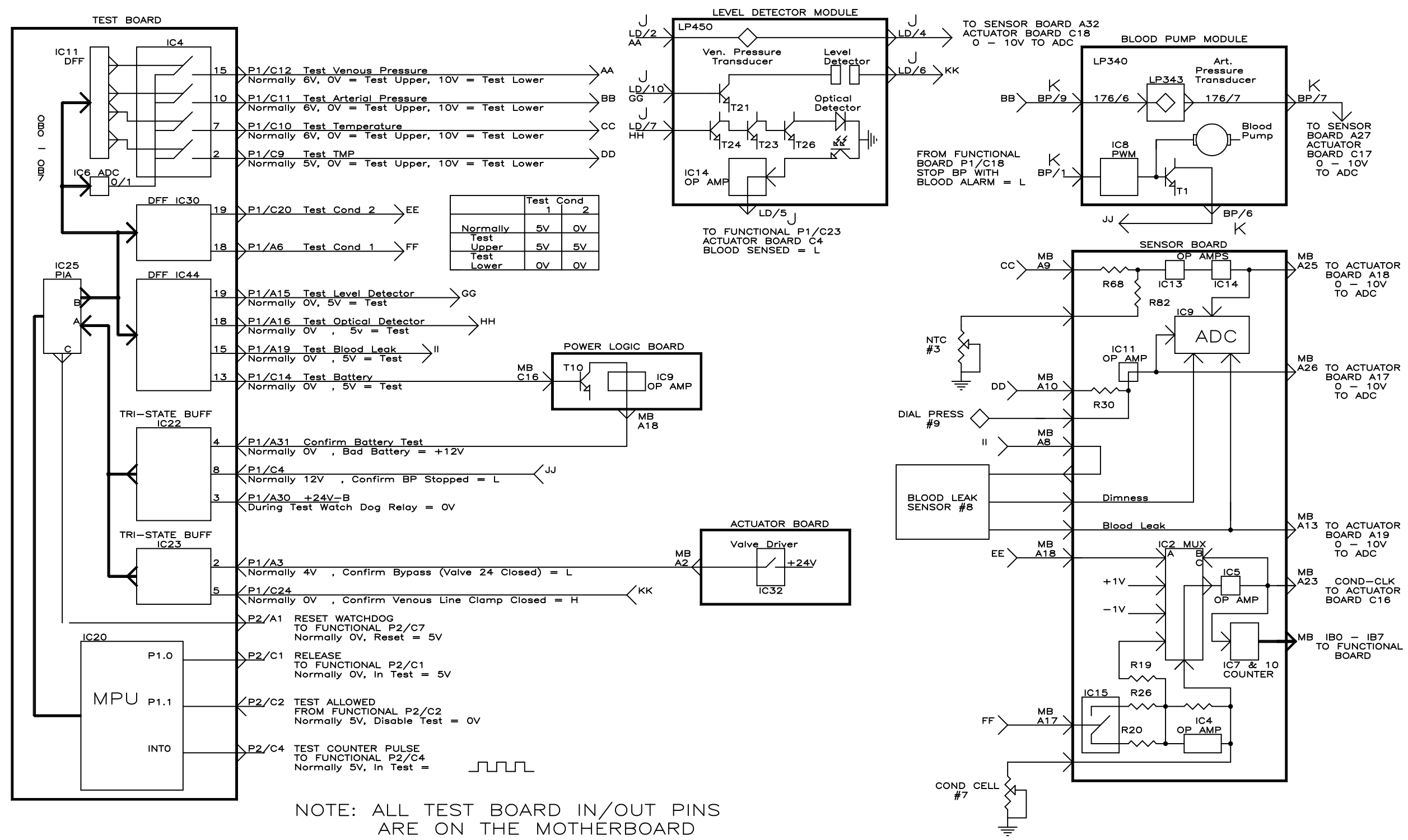

DIAGRAM G TESTING

This document is the property of Fresenius Medical Care, Inc. and contains confidential and trade secret information of Fresenius Medical Care. This document may only be transferred from the custody or control of Fresenius Medical Care only as authorized by Fresenius Medical Care and then only by way of loan for limited purposes. It must not be reproduced in whole or in part and must be returned to Fresenius Medical Care upon request and in all events upon completion of the purpose of the loan. Neither this document nor the information it contains may be used or disclosed to persons not having a need for such use or disclosure consistent with the purpose of the loan, without prior written consent of Fresenius Medical Care.

DATE		NAME		MATERIAL	
DRAWN	3.25.99	B.	LEPARD	2008K ELECTRONIC BLOCK DIAGRAM	
				SCALE NONE	
				REV. A SHEET 7 OF 11	
				290174	
				O:\ACAD\2\290174-7.DWG	
FRESENIUS					

REV	ECO #	BY	DATE	CHK	REVISION
A	7193	BH	6.15.00	JEF	RELEASE

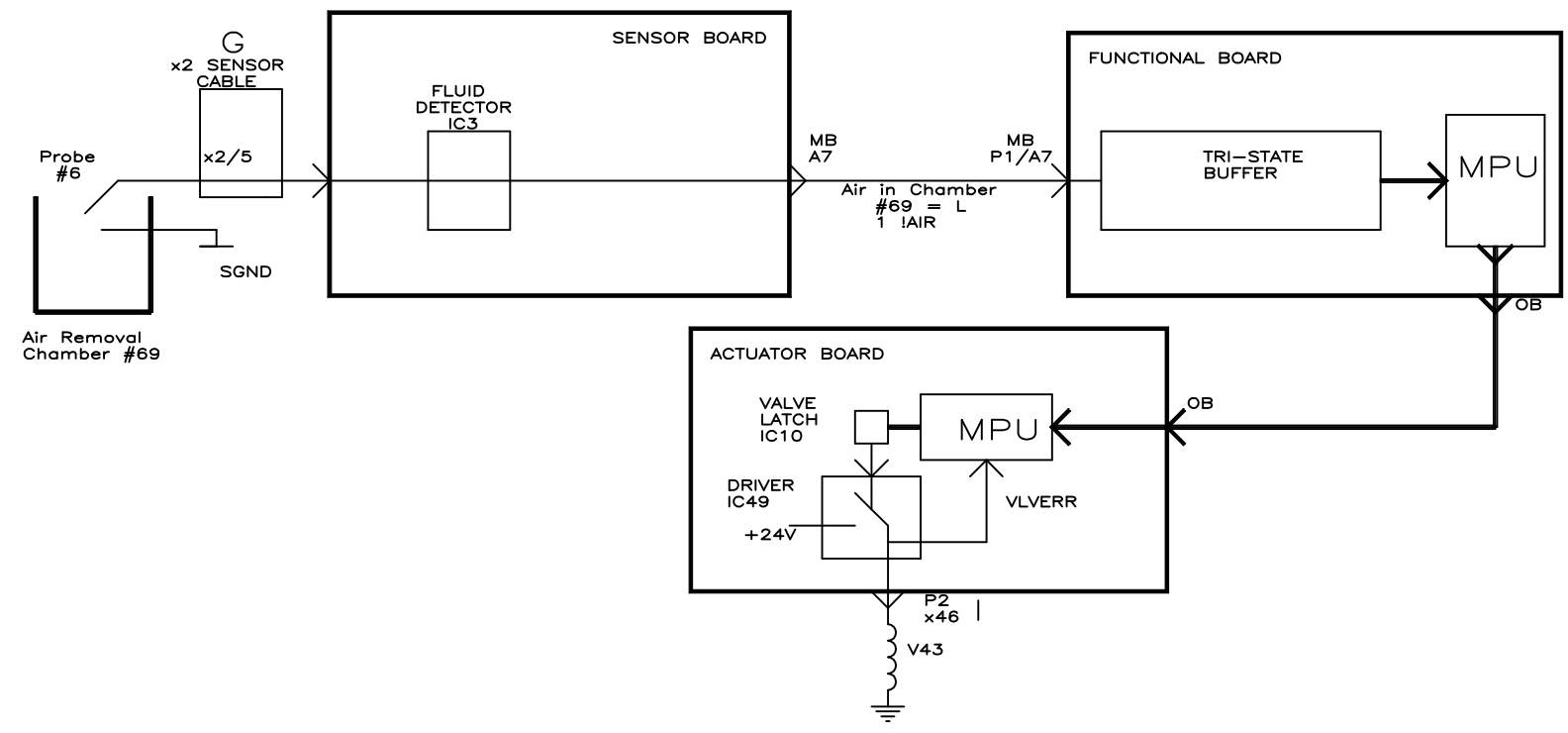

DIAGRAM H FILL PROGRAM

This document is the property of Fresenius Medical Care, Inc. and contains confidential and trade secret information of Fresenius Medical Care. This document may only be transferred from the custody or control of Fresenius Medical Care only as authorized by Fresenius Medical Care and then only by way of loan for limited purposes. It must not be reproduced in whole or in part and must be returned to Fresenius Medical Care upon request and in all events upon completion of the purpose of the loan. Neither this document nor the information it contains may be used or disclosed to persons not having a need for such use or disclosure consistent with the purpose of the loan, without prior written consent of Fresenius Medical Care.

DATE		NAME		MATERIAL	
DRAWN	3.25.99	B.	LEPARD	2008K ELECTRONIC BLOCK DIAGRAM	
				290174	SCALE NONE
				0:\ACAD\2\290174-8.DWG	REV. A SHEET 8 OF 11





REV	ECO #	BY	DATE	CHK	REVISION
A	7193	BH	6.15.00	JEF	RELEASE

CONNECTOR P8 TO MOTHERBOARD

- Pin 1 = Not Connected
- Pin 2 = To functional board P1/C6, actuator board C6
- Pin 3 = To functional board P1/A30, actuator board A5
- Pin 4 = To functional board P1/A31, actuator board C5
- Pin 5 = Ground

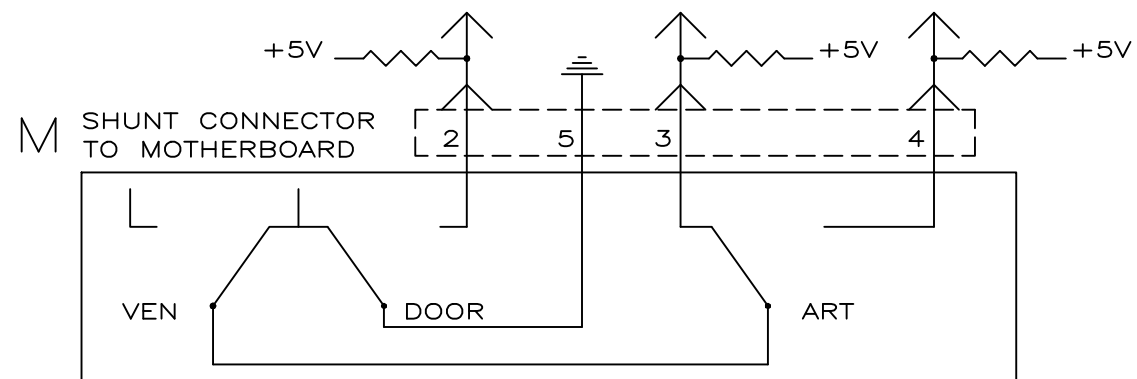

Both lines in shunt; shunt door closed  
 Pin 2 = +5V (Door closed)  
 Pin 3 = 0V (Both lines in shunt)  
 Pin 4 = +5V (Emptying not active)

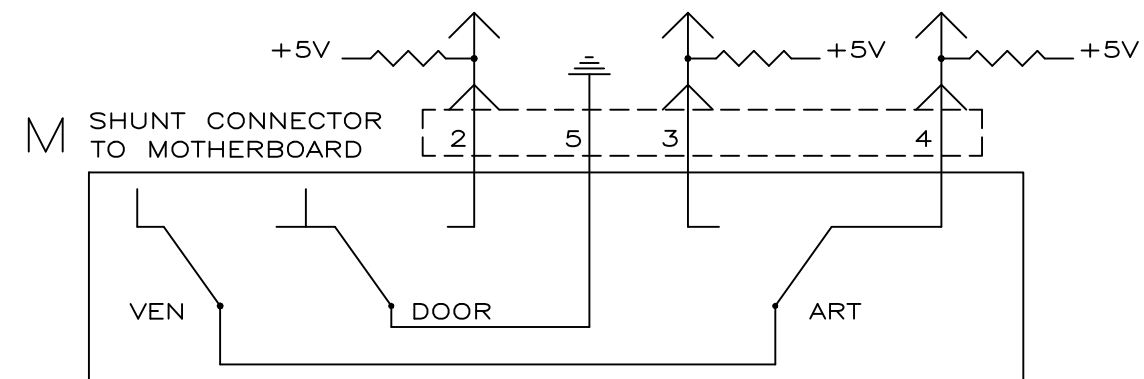

Neither line in shunt; shunt door closed  
 Pin 2 = +5V (Door closed)  
 Pin 3 = +5V (Both dialysate lines not in)  
 Pin 4 = +5V (Emptying not active)

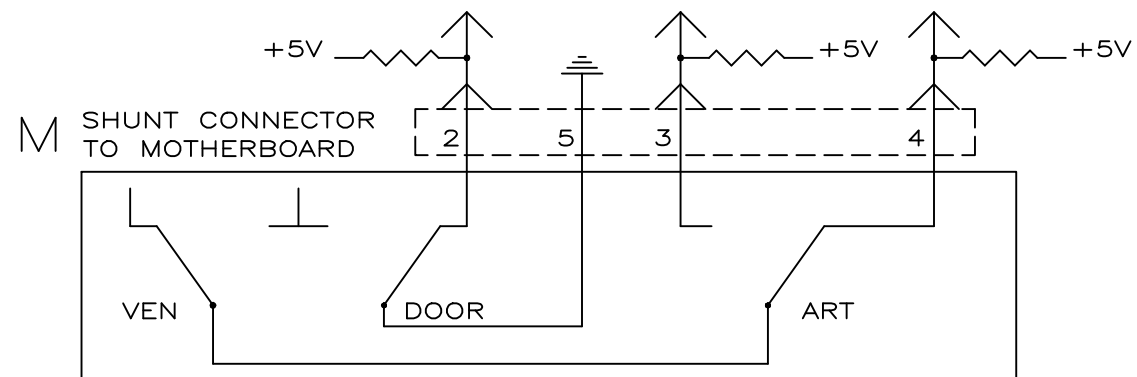

Shunt door open  
 Pin 2 = 0V (Door open)  
 Pin 3 = +5V (Both dialysate lines not in)  
 Pin 4 = +5V (Emptying not active)

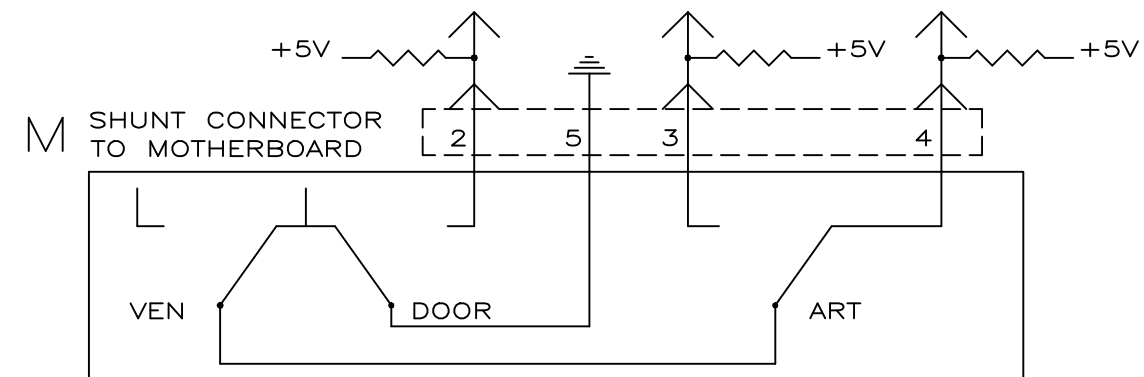

Venous line in shunt, arterial line not in, shunt door closed  
 Pin 2 = +5V (Door closed)  
 Pin 3 = +5V (Venous line in, arterial line not in)  
 Pin 4 = 0V (Emptying activated)

DIAGRAM I SHUNT DOOR SWITCH CONFIGURATIONS

This document is the property of Fresenius Medical Care, Inc. and contains confidential and trade secret information of Fresenius Medical Care. This document may only be transferred from the custody or control of Fresenius Medical Care only as authorized by Fresenius Medical Care and then only by way of loan for limited purposes. It must not be reproduced in whole or in part and must be returned to Fresenius Medical Care upon request and in all events upon completion of the purpose of the loan. Neither this document nor the information it contains may be used or disclosed to persons not having a need for such use or disclosure consistent with the purpose of the loan, without prior written consent of Fresenius Medical Care.

DATE		NAME		MATERIAL	
DRAWN	3.25.99	B.	LEPARD	2008K ELECTRONIC BLOCK DIAGRAM	
				290174	SCALE NONE
				0:\ACAD\2\290174-9.DWG	REV. A SHEET 9 OF 11



REV	ECO #	BY	DATE	CHK	REVISION
A	7193	BH	6.15.00	JEF	RELEASE

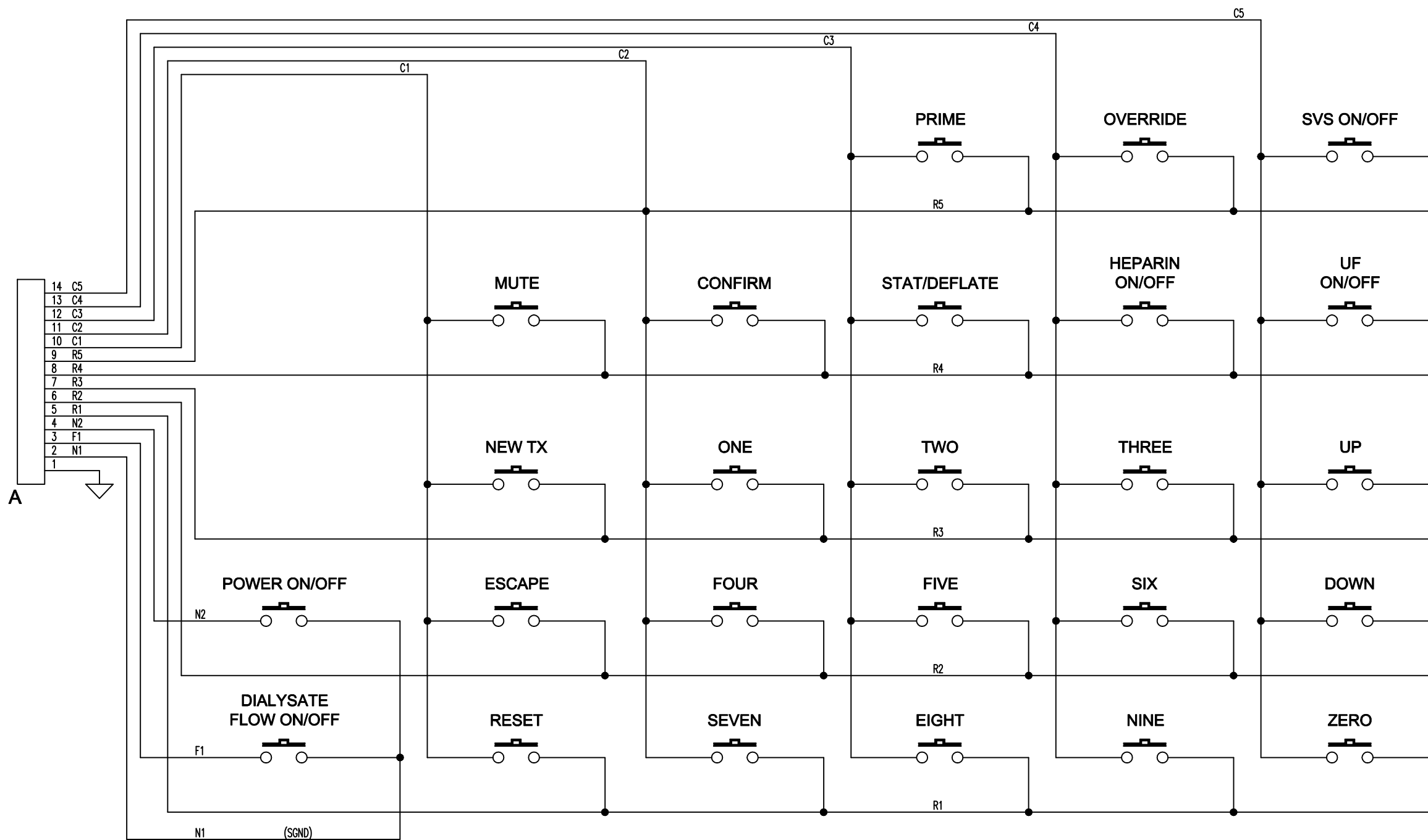

DIAGRAM J FRONT PANEL SWITCH MATRIX

This document is the property of Fresenius Medical Care, Inc. and contains confidential and trade secret information of Fresenius Medical Care. This document may only be transferred from the custody or control of Fresenius Medical Care only as authorized by Fresenius Medical Care and then only by way of loan for limited purposes. It must not be reproduced in whole or in part and must be returned to Fresenius Medical Care upon request and in all events upon completion of the purpose of the loan. Neither this document nor the information it contains may be used or disclosed to persons not having a need for such use or disclosure consistent with the purpose of the loan, without prior written consent of Fresenius Medical Care.

DATE		NAME		MATERIAL	
DRAWN	3.25.99	B.	LEPARD	2008K ELECTRONIC BLOCK DIAGRAM	
				290174	SCALE NONE
				0:\ACAD\2\290174-10.DWG	REV. A SHEET 10 OF 11



REV	ECO #	BY	DATE	CHK	REVISION
A	7193	BH	6.15.00		RELEASE

**CARD CAGE**  
LEFT TO RIGHT:  
POWER LOGIC BOARD  
ACTUATOR BOARD  
FUNCTIONAL BOARD  
TEST BOARD  
SENSOR BOARD

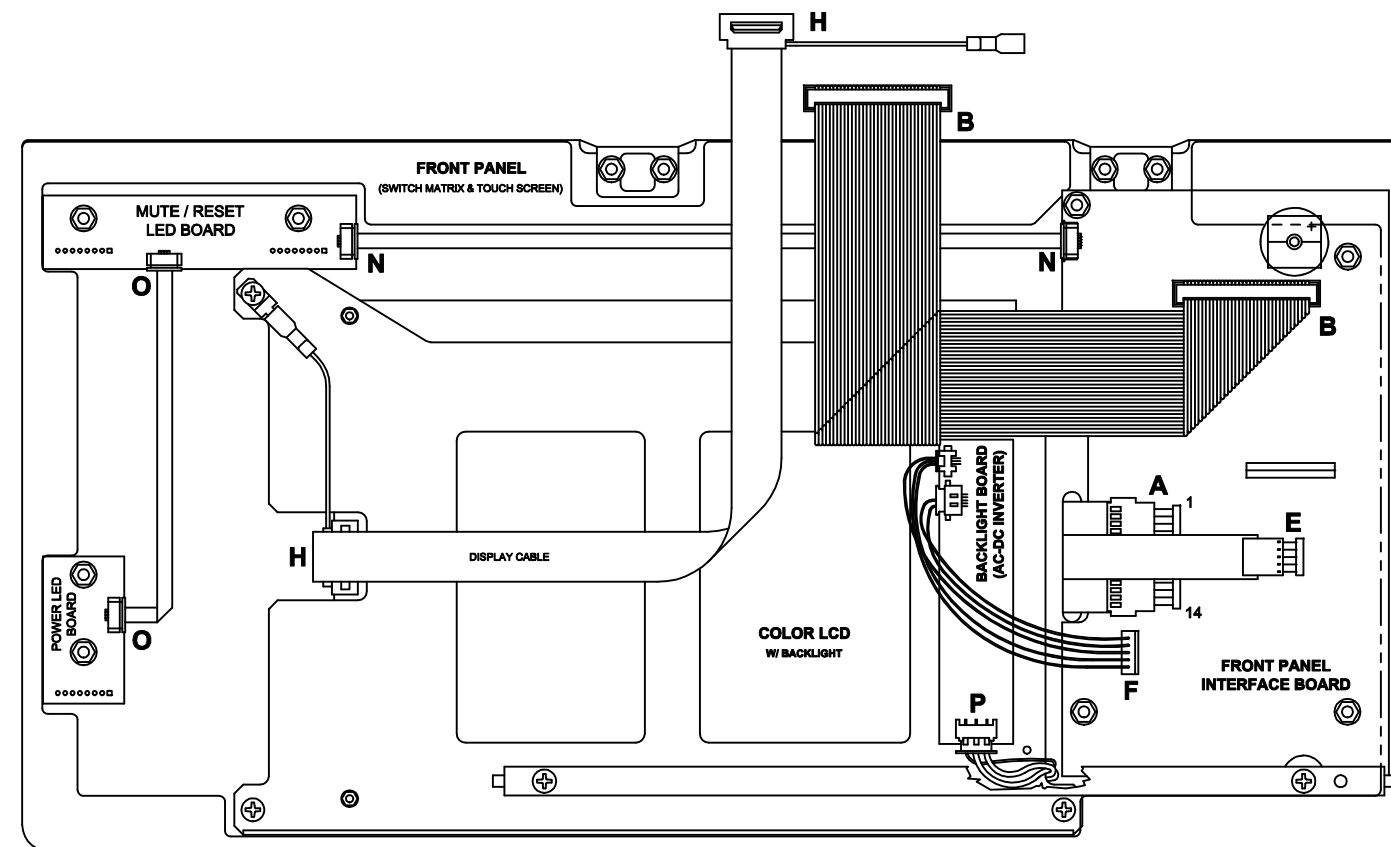
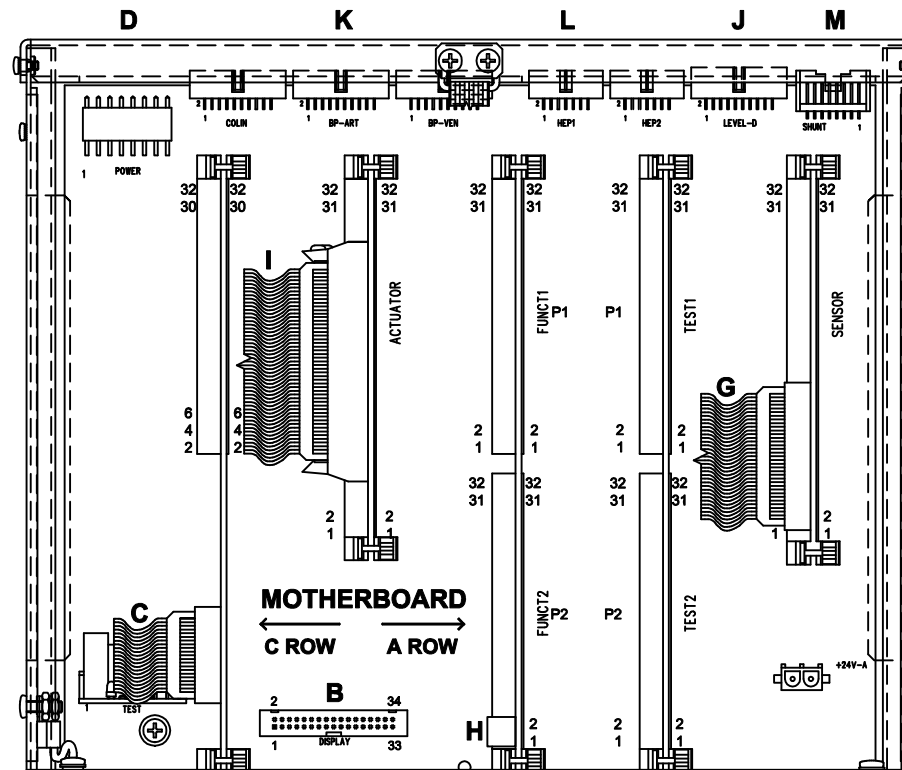

DIAGRAM K CARD CAGE AND DISPLAY BOARD

This document is the property of Fresenius Medical Care, Inc. and contains confidential and trade secret information of Fresenius Medical Care. This document may only be transferred from the custody or control of Fresenius Medical Care only as authorized by Fresenius Medical Care and then only by way of loan for limited purposes. It must not be reproduced in whole or in part and must be returned to Fresenius Medical Care upon request and in all events upon completion of the purpose of the loan. Neither this document nor the information it contains may be used or disclosed to persons not having a need for such use or disclosure consistent with the purpose of the loan, without prior written consent of Fresenius Medical Care.

		MATERIAL	
DATE	NAME		
DRAWN 3.25.99	B. LEPPARD	2008K ELECTRONIC BLOCK DIAGRAM	
		SCALE NONE	
		290174	
		REV. A SHEET 11 OF 11	
		O:\ACAD\2\290174-11.DWG	

