

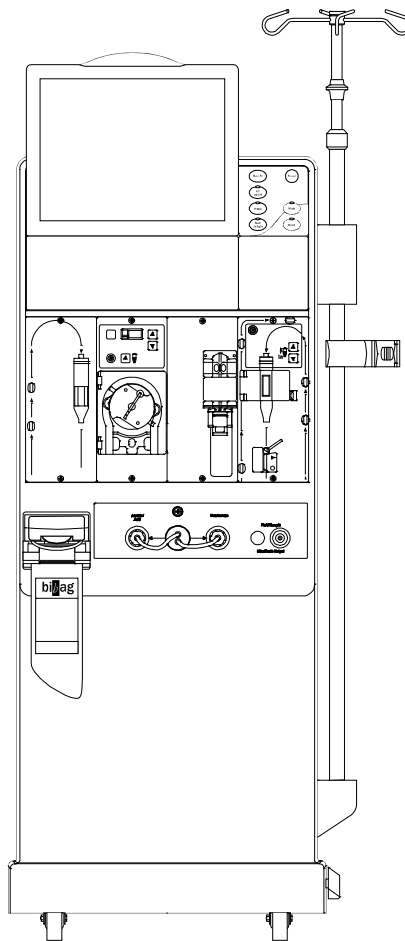

**FRESENIUS
MEDICAL CARE**

bi^zag[®]



2008T Hemodialysis Machine bi^zag System Operator's Instructions

2008T Hemodialysis Machine bibag System Operator’s Instructions

© Copyright 2009 – 2020 Fresenius USA, Inc.—All Rights Reserved

This document contains proprietary information of Fresenius Medical Care Renal Therapies Group, LLC and its affiliates (“Fresenius Medical Care”). The contents of this document may not be disclosed to third parties, copied, or duplicated in any form, in whole or in part, without the prior written permission of Fresenius Medical Care.

Fresenius Medical Care, the triangle logo, 2008, and bibag are trademarks of Fresenius Medical Care Holdings, Inc., and/or its affiliated companies. All other trademarks are the property of their respective owners.

Maintenance, calibration and other technical information may be found in the bibag V2.0 Technician’s manual, P/N 490188.

Contact Fresenius Medical Care Technical Support for applicable Field Service Bulletins. The spare parts manual for the model 2008T and other information may be found on our web site at www.fmcna.com

Caution: US Federal law restricts this device to sale only by or on the order of a physician. Frequency, duration, and parameters of treatment are to be determined by the prescribing physician.

Indications for Use: The 2008T hemodialysis machine is indicated for acute and chronic dialysis therapy.

bibag Indications for Use: The Fresenius Medical Care bibag system is used with Fresenius Medical Care three stream proportioning hemodialysis systems equipped with the bibag module such as the 2008T hemodialysis machine and is intended for use in bicarbonate hemodialysis for acute and chronic renal failure. The bibag system is intended for extracorporeal bicarbonate hemodialysis according to a physician’s prescription.

Table of Contents

Operating Instructions	3
General Warnings	3
Selecting concentrates in Service Mode	4
bibag System Details	5
Using the bibag system for a dialysis treatment	6
Changing the bibag disposable during treatment	7
Emptying a bibag disposable at the end of treatment	8
Using the blue bicarbonate connector	9
Cleaning the bibag connector.....	9
Troubleshooting	10
2008T Machine with bibag System Specifications	20

Operating Instructions

These instructions are for the bibag hardware option with Functional Board software 2.35 or greater and Actuator Board software 2.15 or greater. The bibag system must only be operated with the 2008T hemodialysis machine and according to these instructions and those of the *2008T Hemodialysis Machine Operator's Manual* P/N 490122.

General Warnings



Warning: The concentrate displayed on the screen must match the labels on the acid container. Make certain there is enough concentrate in the containers to complete the treatment.

Warning: The specific concentrate, sodium, and bicarbonate settings must be prescribed by a physician.

Warning: Acid concentrate, bicarbonate concentrate, and water must be of the appropriate quality to ensure local regulation regarding safety and performance of the final dialysate is met. Dilute immediately prior to application only.

Warning: Always verify the conductivity and approximate pH of the final dialysate solution through independent means before initiating dialysis and when switching from the bibag system to liquid bicarbonate*. Verify that the pH and the conductivity meet the requirements specified in ANSI/AAMI RD52, which are pH within the range of 6.9-7.6 and conductivity within $\pm 5\%$ of the nominal machine value.

***Note:** If alternative bicarbonate concentrate sources are used (jugs or central delivery) the end user must ensure the bicarbonate is of appropriate quality and is prepared per manufacturer's instructions.

Warning: Replace a leaking bag immediately. Spills can cause damage to carpeting and other surfaces. To contain such spills, the machine should be on a spill-tolerant surface. Spills can cause slips and falls; clean up spills immediately.

Warning: The acid and bicarbonate pressures must not exceed 10 psi when using a Central Delivery System. It may be necessary to use pressure regulators in order to reach proper conductivity.



Caution: Only the bags manufactured by Fresenius Medical Care North America may be used in the bibag connector.



Note: When the bibag connector is installed, the online pressure holding test becomes mandatory. For more information, see the Online Pressure Holding Test section of the *2008T Hemodialysis Machine Operator's Manual* P/N 490122.

Note: The bibag disposable must hang freely below the bibag connector. Make certain that there are no jugs or other objects obstructing or touching the bibag disposable.



Note: The Diasafe Plus filter is required when the *bibag* system is in use.

Note: Pressing the **Mute** key will silence an alarm for two minutes. The following alarms are muted for an additional four minutes (for a total of six minutes) when using the *bibag* system:

- Conductivity Low and Conductivity High
 - *bibag*: Cond Low
 - Bicarb: Cond Low and Bicarb: Cond High
 - Bicarb Cond 2 Low and Bicarb Cond 2 High
 - Low Temperature and High Temperature
-

Selecting concentrates in Service Mode

The “45x” concentrate family must be selected in order to use the *bibag* system. When a 45x type concentrate is selected with the *bibag* module installed, the machine will automatically detect whether or not a *bibag* disposable is connected upon entering Dialysis Mode.



Note: Once the concentrate type has been selected, it may be necessary to add concentrates from the preprogrammed catalog or add an entirely new concentrate. See the “Adding New Concentrates or Changing the Type” section in the *2008T Hemodialysis Machine Operator’s Manual* P/N 490122.

bi*bag* System Details

The *bi*bag system is a hardware option that allows the usage of a dry bicarbonate powder to generate dialysate solution for the 2008T hemodialysis machine. The *bi*bag disposable is a bag filled with dry bicarbonate powder with special inlet and outlet ports. The *bi*bag disposable connects to the 2008T machine via a special connector to the left of the concentrate ports. Underneath the *bi*bag door on the connector, the bag hangs on two nozzles which allow for the entry of purified water and the exit of bicarbonate concentrate solution. A door handle locks the *bi*bag door in place over the bag.

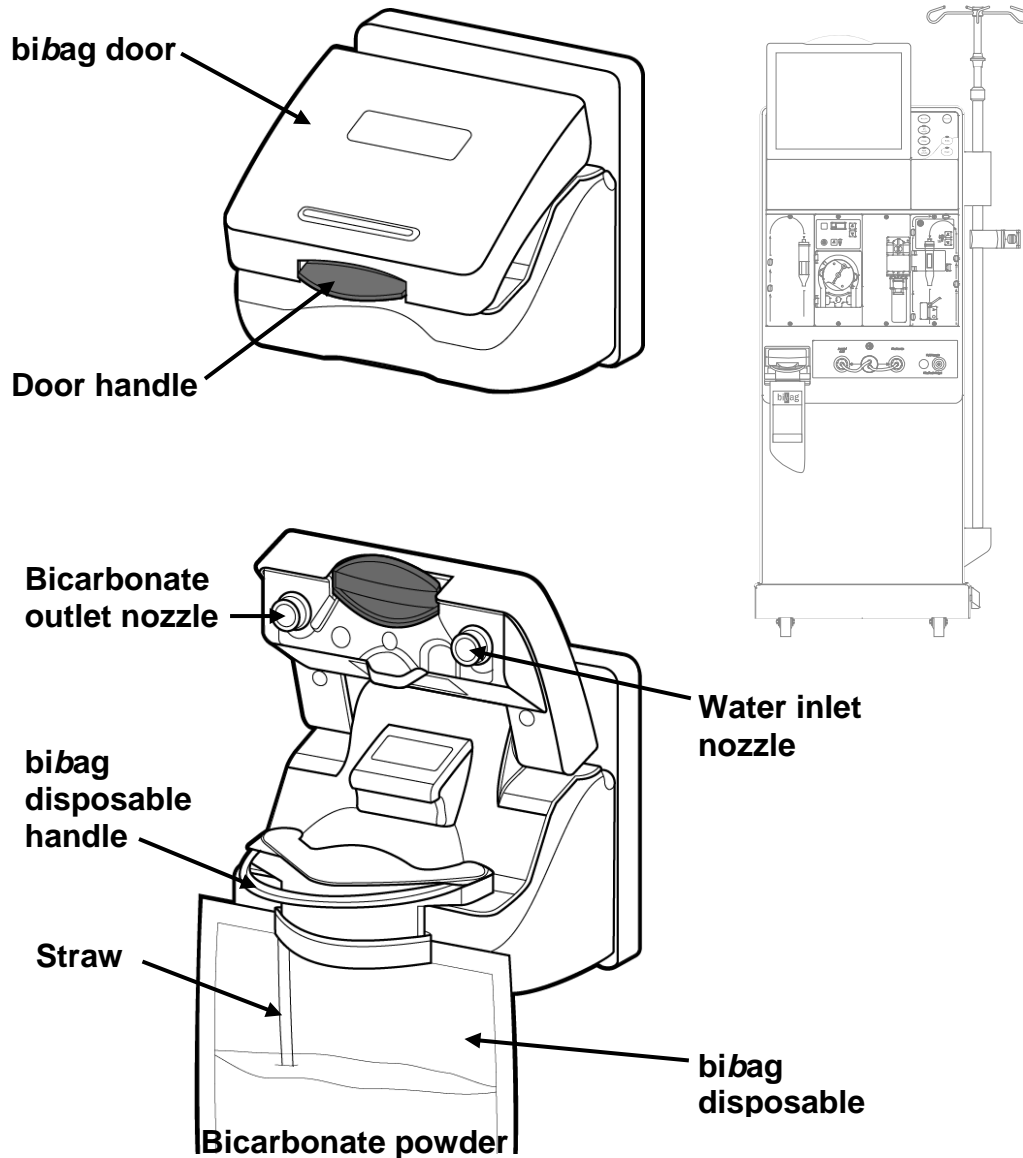

Figure 1 – *bi*bag connector: door closed and *bi*bag disposable inserted with door open

Using the *bi*bag system for a dialysis treatment

Begin with typical treatment setup (as explained in Chapter 2, “Preparing the Dialysate Delivery System” of the *2008T Hemodialysis Machine Operator’s Manual* P/N 490122). If the treatment is just beginning, use the instructions below before entering Dialysis mode from the “Select Program” screen.



Note: The machine will not allow use of the *bi*bag disposable unless the 45x concentrate family is selected in Service Mode. The blue bicarbonate connector must be inserted into the machine’s bicarbonate port during a *bi*bag-based treatment.

1. Make sure the red acid concentrate connector is connected to the acid concentrate.
2. Remove the white plastic seal from underneath the water and bicarbonate nozzles of the *bi*bag disposable.
3. Open the *bi*bag door on the machine by lifting up on the dark-gray handle.
4. With the white *bi*bag handle facing outward (see Figure 1), hang the *bi*bag disposable on the *bi*bag connector nozzles. Push it down until it is fully seated on the *bi*bag connector nozzles.



Note: The *bi*bag disposable must hang freely below the *bi*bag connector. Make certain that there are no jugs or other objects obstructing or touching the *bi*bag disposable.

5. Close the door, making sure it latches firmly in place. An audible click indicates the door is closed. After the acid concentrate source and the *bi*bag disposable are connected, resume with “Preparing the Dialysate Delivery System” step 4 of the *2008T Hemodialysis Machine Operator’s Manual* (P/N 490122) to put the 2008T hemodialysis machine into Dialysis Mode. When the machine is ready (water at minimum temperature and no air in the hydraulics), it will fill the bag with heated water to be used as a bicarbonate concentrate for dialysate production.



Note: Dialysate flow must be ON in order to fill the *bi*bag disposable with heated water.

Note: Do not remove the blue bicarbonate connector from the machine’s bicarbonate port while using the *bi*bag system for treatment. Doing so will stop the flow to and from the *bi*bag disposable.

Note: If a “*bi*bag: Cond Low” alarm occurs when there is only about one inch (2.5cm) of bicarbonate left at the bottom of the *bi*bag disposable, the bag is at the end of its useful life. Replace the bag with a fresh bag (see the next page for instructions).

Note: The *bi*bag disposable contains a fixed volume of bicarbonate powder. Refer to the tables on the next page to verify that enough run time (including any set-up time and potential pre-treatment delays) is available to complete a treatment using one bag.

Table 1: 650g *bi*bag Disposable Estimated Run Time (Minutes)*

650g		Bicarbonate Setting (mEq/L or mmol/L)																
		40	39	38	37	36	35	34	33	32	31	30	29	28	27	26	25	24
Dialysate flow QD (mL/min)	800	180	185	189	195	200	206	212	218	225	232	240	248	257	267	277	288	300
	700	206	211	217	222	229	235	242	249	257	265	274	284	294	305	316	329	343
	600	240	246	253	259	267	274	282	291	300	310	320	331	343	356	369	384	400
	500	288	295	303	311	320	329	339	349	360	372	384	397	411	427	443	461	480
	400	360	369	379	389	400	411	424	436	450	465	480	497	514	533	554	576	600
	300	480	492	505	519	533	549	565	582	600	619	640	662	686	711	738	768	800
	200	720	738	758	778	800	823	847	873	900	929	960	993	1029	1067	1108	1152	1200

Table 2: 900g *bi*bag Disposable Estimated Run Time (Minutes)*

900g		Bicarbonate Setting (mEq/L or mmol/L)																
		40	39	38	37	36	35	34	33	32	31	30	29	28	27	26	25	24
Dialysate flow QD (mL/min)	800	240	246	253	259	267	274	282	291	300	310	320	331	343	356	369	384	400
	700	274	281	289	297	305	313	323	332	343	354	366	378	392	406	422	439	457
	600	320	328	337	346	356	366	376	388	400	413	427	441	457	474	492	512	533
	500	384	394	404	415	427	439	452	465	480	495	512	530	549	569	591	614	640
	400	480	492	505	519	533	549	565	582	600	619	640	662	686	711	738	768	800
	300	640	656	674	692	711	731	753	776	800	826	853	883	914	948	985	1024	1067
	200	960	985	1011	1038	1067	1097	1129	1164	1200	1239	1280	1324	1371	1422	1477	1536	1600

* Run times are estimates and may vary per unit protocol. Run times include estimated preparation and treatment time. Highlighted run times indicate 10+ hours of treatment time.

** To estimate run times for bicarbonate settings lower than what is listed in the table, use a bicarbonate selection of 24 (mEq/L or mmol/L).

Changing the *bi*bag disposable during treatment



Note: When changing the *bi*bag disposable during treatment, the automated empty feature cannot be used so the bag will need to be emptied manually.

Note: If a bag is changed during treatment, a pause of 6-10 minutes should be expected as the new bag fills. The dialysis machine will automatically go into bypass mode until the new bag is on-line and conductivity comes into the acceptable range.

If the *bi*bag disposable needs to be changed during the treatment, use the following steps:

1. Lift up on the dark-gray *bi*bag door handle to open the *bi*bag door.
2. Wait 30 seconds to relieve the pressure in the bag.
3. Lift up the *bi*bag disposable by the handle, remove the used bag and dispose of it per unit protocol. Since the used bag is not empty of fluid, be careful to prevent spills.



Note: If disposing of leftover bicarbonate solution down a drain, be sure to run plenty of hot water down the drain too. This will help prevent bicarbonate buildup in the plumbing.

4. For the new *bi*bag disposable, remove the white plastic seal from underneath the water and bicarbonate nozzles. With the white *bi*bag handle facing outward, hang the bag on the machine's *bi*bag connector nozzles. Push it down until it is fully seated on the *bi*bag connector nozzles.
5. Close the *bi*bag door, making sure it latches firmly in place. An audible click indicates the door is closed. The treatment will resume after the machine fills the bag with heated water.

Emptying a *bi*bag disposable at the end of treatment



Note: The Empty *bi*bag feature cannot be used when blood is sensed or the Tx Clock is running. The **Empty *bi*bag** button is also unavailable during a “*bi*bag: Bag Leak” alarm.

Note: The *bi*bag disposable may also be emptied manually; see page 7 for more information.

At the end of the treatment, a blue **Empty *bi*bag** button is displayed in the upper right corner of the “Dialysate” screen (see Figure 2) to empty the bag for easy disposal.

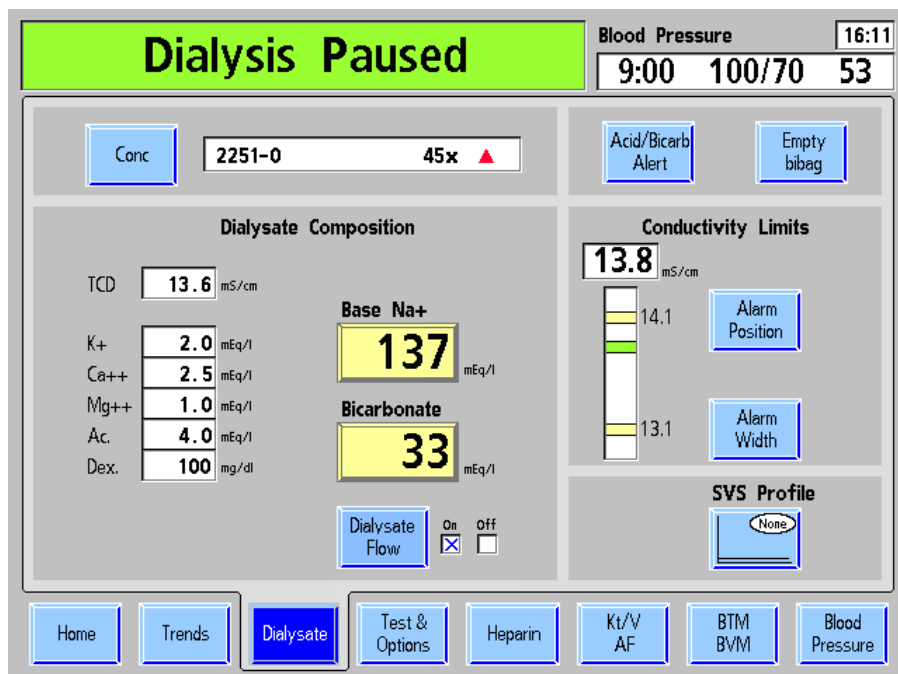

Figure 2 – Empty *bi*bag button on the “Dialysate” screen

Follow the steps below to empty the *bi*bag disposable at the end of a treatment:

1. Select the **Empty *bi*bag** button and press the **CONFIRM** key to begin emptying the *bi*bag disposable. Any fluid remaining in the bag will be sent out the machine drain line.



Note: The *bi*bag disposable and the dialyzer cannot be emptied at the same time. To run the Empty *bi*bag program, both dialysate lines must either be on the shunt or on the dialyzer.

2. When the *bi*bag disposable is empty of fluid, the Status Box will display the message “*bi*bag: Emptied.”
3. Lift up on the dark-gray *bi*bag door handle to open the *bi*bag door. Remove the bag and dispose of it per unit protocol.
4. Close the *bi*bag door securely, making sure that the door latches into place (two clicks should be heard).

Using the blue bicarbonate connector

Machines with the *bi*bag connector may still be used for liquid bicarbonate-based dialysis when the *bi*bag disposable is not in use. To switch to liquid bicarbonate-based dialysis:

1. Make sure that the *bi*bag door is closed without a bag on the *bi*bag connector.
2. Turn off the dialysate flow by selecting and confirming the **Dialysate Flow on/off** toggle-button on the “Dialysate” screen.
3. Pull the blue bicarbonate connector from its port and insert it into a central delivery liquid bicarbonate supply or a jug containing sufficient liquid bicarbonate concentrate for an entire treatment.
4. Turn the dialysate flow back on by selecting and confirming the **Dialysate Flow on/off** toggle-button on the “Dialysate” screen.



Warning: Always verify the conductivity and approximate pH of the final dialysate solution through independent means before initiating dialysis and when switching from the *bi*bag system to liquid bicarbonate*. Verify that the pH and the conductivity meet the requirements specified in ANSI/AAMI RD52, which are pH within the range of 6.9-7.6 and conductivity within $\pm 5\%$ of the nominal machine value.

***Note:** If alternative bicarbonate concentrate sources are used (jugs or central delivery) the end user must ensure the bicarbonate is of appropriate quality and is prepared per manufacturer’s instructions.

Cleaning the *bi*bag connector

The *bi*bag connector is connected to the 2008T machine’s hydraulics so running rinse or disinfection programs from the “Select Program” screen will also rinse or disinfect the *bi*bag connector.

To prevent bicarbonate buildup on the *bi*bag connector:

- Clean the exterior of the sealing area of the *bi*bag nozzles with very dilute 1:100 bleach every day before running a rinse program.
- Run an Acid Clean program at the end of every treatment day before running a Heat Disinfect program.

The exterior of the dialysis machine, including the *bi*bag connector, should be cleaned after every treatment. It can be cleaned with very dilute bleach or other suitable hospital disinfectant. Freshly prepared dilute bleach solution (1:100) is currently recommended by the Center for Disease Control as a suitable disinfectant for the Hepatitis virus. Because surface contamination is the general mode of transmission for this type of virus, thorough cleaning of the 2008T machine exterior is essential.



Warning: Do not open the *bi*bag door during a Heat Disinfection, as serious injury may occur. Keep the *bi*bag door closed when running any rinse or disinfection program.

Warning: A Rinse program must be run after cleaning the sealing area of the *bi*bag nozzles on the *bi*bag connector to rinse away residual disinfectant.

Troubleshooting

All status messages (operational alarms, warnings, dialogues, and advisories) are displayed on the control panel screen. These messages are generated due to conditions and events that occur in the machine during operation. These messages will reset when the condition causing the message is corrected. In some cases, the operator must reset them. The following is a list of bibag system-related messages. A full list of 2008T machine messages may be found in the *2008T Hemodialysis Machine Operator's Manual* P/N 490122.



Warning: Performing the recommended action may or may not clear the alarm, warning or advisory messages displayed. Patient treatment shall not proceed until the conditions causing these messages are corrected and the messages cleared.



Note: There are alarm messages that may be similar. Please take care that you read appropriate message to determine the “Action required” for troubleshooting.

Message	Purpose of Message	Type	Action Required
Acid Press Calib Err	bi <i>bag</i> system pressure calibration error.	Advisory	Turn machine power off and back on. If message is not cleared, take the machine out of service and alert a qualified service technician.
Active Pressure Regulator Uncalibrated	Pressure regulator not calibrated.	Alarm	Turn machine power off and back on. If the alarm is not cleared, take the machine out of service and alert a qualified service technician.
bi <i>bag</i> : +5 V Error	Electronic self-test, power supply limits exceeded.	Alarm	Turn machine power off and back on. If the alarm is not cleared, take the machine out of service and alert a qualified service technician.
bi <i>bag</i> : -5 V Error	Electronic self-test, power supply limits exceeded.	Alarm	Turn machine power off and back on. If the alarm is not cleared, take the machine out of service and alert a qualified service technician.
bi <i>bag</i> : +12 V Error	Electronic self-test, power supply limits exceeded.	Alarm	Turn machine power off and back on. If the alarm is not cleared, take the machine out of service and alert a qualified service technician.
bi <i>bag</i> : Bag Leak	A leak has been detected in the bag.	Water Alarm	Open bi <i>bag</i> door, wait 30 seconds to relieve the pressure, and remove the bag. Place a new bag on the connector and close the bi <i>bag</i> door.
bi <i>bag</i> : Bag On	The bag is on the connector when user is either attempting to run a cleansing/disinfecting program or using acetate. Or The blue bicarbonate connector is out of the bicarbonate port when a bag is on the bi <i>bag</i> connector.	Water Alarm	Remove the bag from the bi <i>bag</i> connector if using acetate or attempting to run a cleansing/disinfecting program. Or Plug the blue bicarbonate connector back into the bicarbonate port on the machine.
bi <i>bag</i> : Bic Pump Locked	The bicarbonate pump has been air locked for over two minutes.	Water Alarm	If during treatment, rinse back the patient's blood and disconnect the patient from the machine. Run a Rinse program to clear the alarm. If the alarm is not cleared, take the machine out of service and alert a qualified service technician.
bi <i>bag</i> Board Failure	bi <i>bag</i> Interface Board cannot boot up.	Alarm	Turn machine power off and back on. If alarm is not cleared, take the machine out of service and alert a qualified service technician.
bi <i>bag</i> : Chamber Venting	The system is venting and the machine is in bypass mode.	Advisory	Advisory only. No action is required.  Note: If this message occurs repeatedly, open the bi <i>bag</i> door, wait 30 seconds to relieve the pressure, and lift the bag off the bi <i>bag</i> connector nozzles to vent the air. With the white bi <i>bag</i> handle facing outward, hang the bi <i>bag</i> disposable back on the connector nozzles. Close the bi <i>bag</i> door, making sure it latches firmly in place. An audible click indicates the door is closed.

Message	Purpose of Message	Type	Action Required
bibag: Cond Calib Err	Electronic self-test: <i>bibag</i> conductivity sensor calibration error.	Alarm	Turn machine power off and back on. If the alarm is not cleared, take the machine out of service and alert a qualified service technician.
bibag: Cond High	The actual or measured <i>bibag</i> conductivity has exceeded the high conductivity alarm limit when using the <i>bibag</i> disposable. The machine is in bypass mode.	Water Alarm	Wait five minutes for conductivity to stabilize. If the appropriate conductivity cannot be reached, connect a new bag. If the alarm is still not cleared, return blood to the patient. Take the machine out of service and alert a qualified service technician.
bibag: Cond Low	The actual or measured <i>bibag</i> conductivity is below the low conductivity alarm limit when using the <i>bibag</i> disposable. The machine is in bypass mode. The <i>bibag</i> disposable may also be nearly empty.	Water Alarm	<p>Check the <i>bibag</i> disposable: if there is only about one inch (2.5 cm) of bicarbonate left at the bottom of the bag, replace the bag. Open the <i>bibag</i> door, wait 30 seconds to relieve the pressure, and remove the bag. Place a fresh bag back on the connector and close the door.</p> <p>Wait five minutes for conductivity to stabilize.</p> <p>If conductivity alarm persists:</p> <ol style="list-style-type: none"> 1) Turn off the dialysate flow by selecting and confirming the Dialysate Flow on/off toggle-button on the “Dialysate” screen. 2) Gently massage the base of the <i>bibag</i> disposable to better mix the bicarbonate powder and remove any trapped air. 3) Turn the dialysate flow back on by selecting and confirming the Dialysate Flow on/off toggle-button on the “Dialysate” screen. <p>If the appropriate conductivity cannot be reached, connect a new bag.</p> <p>If conductivity alarm persists,</p> <ol style="list-style-type: none"> 1) Turn off the dialysate flow by selecting and confirming the Dialysate Flow on/off toggle-button on the “Dialysate” screen. 2) Leaving the bag on the connector, pull the blue bicarbonate connector out of its rinse port. 3) Check for a clogged filter screen in the blue bicarbonate connector handle. Clean if necessary with purified water. Verify that the connector and filter assembly are tightly screwed together with no air leak. 4) Insert the blue bicarbonate connector back into its rinse port. 5) Turn the dialysate flow back on by selecting and confirming the Dialysate Flow on/off toggle-button on the “Dialysate” screen. <p>If the conductivity alarm still cannot be cleared, rinse back the patient’s blood and disconnect the patient from the machine. Run an Acid Clean program followed by a complete rinse cycle. Test machine operation.</p> <p>If conductivity alarm still persists, take the machine out of service and alert a qualified service technician.</p>

Message	Purpose of Message	Type	Action Required
bibag: Cond Sensor Err	The <i>bi</i> bag conductivity sensor is not reading the correct conductivity. The machine is in bypass mode.	Advisory	Insert the blue bicarbonate connector into an appropriate liquid bicarbonate source Or To use the <i>bi</i> bag disposable: If during treatment, rinse back the patient's blood and disconnect the patient from the machine. Run a Rinse program until message is cleared. If the alarm is not cleared, take the machine out of service and alert a qualified service technician.
bibag: Door Error	Sensor error.	Advisory	Turn machine power off and back on. If the alarm is not cleared, return the blood to the patient if alarm occurs during treatment. Take the machine out of service and alert a qualified service technician.
bibag: Door Open	The <i>bi</i> bag door is open. The machine is in bypass mode.	Water Alarm	Close the <i>bi</i> bag door to continue.
bibag: Emptied	The <i>bi</i> bag emptying program has completed. The emptied bag must be removed from the <i>bi</i> bag connector.	Advisory	Open the <i>bi</i> bag door and remove the bag to continue.
bibag: Empty Too Long	The bag has been emptying longer than five minutes.	Water Alarm	Make sure that the blue bicarbonate connector is firmly plugged into the bicarbonate port. If the message is not cleared, remove bag without emptying and alert a qualified service technician.
bibag: Emptying	The bag is being emptied by the machine.	Advisory	No action required, wait until the machine has finished emptying the bag to continue.
bibag: Filling	The bag is filling with water.	Advisory	Advisory only. No action is required.
bibag: I2C Error	I ² C communication problem.	Alarm	Turn machine power off and back on. If the alarm is not cleared, return the blood to the patient if alarm occurs during treatment. Take the machine out of service and alert a qualified service technician.
bibag: In Bypass	A <i>bi</i> bag alarm or process was occurring when the operator attempted to run prime recirc. The machine is in bypass mode.	Advisory	Advisory only. No action is required. Wait until the message has cleared before selecting prime recirc again.
bibag: No Bag	A bag must be on the connector to continue. The machine is in bypass mode.	Water Alarm	Place a bag on the <i>bi</i> bag connector and close the door to continue.
bibag: No Comm.	The <i>bi</i> bag interface board is not communicating with the actuator board.	Alarm	Turn machine power off and back on. If the alarm is not cleared, take the machine out of service and alert a qualified service technician.

Message	Purpose of Message	Type	Action Required
bibag: PHT Failed	The <i>bibag</i> online Pressure Holding Test has failed. The machine is in bypass mode.	Water Alarm	<p>If the PHT failed <i>on the “Select Program” screen</i>:</p> <ul style="list-style-type: none"> • Turn machine power off and back on to rerun the test. • If the failure message is repeated on the next test, take the machine out of service and alert a qualified service technician. <p>If the PHT failed <i>in Dialysis Mode</i>:</p> <ul style="list-style-type: none"> • Make sure there are no concentrate jugs or other objects obstructing the bag or pressing against it. • Check the machine for leaks. If no leaks are detected: <ul style="list-style-type: none"> ○ Open the <i>bibag</i> door, wait 30 seconds to relieve the pressure, and remove the bag. ○ Place the bag back on the connector and close the door. The <i>bibag</i> online PHT will run again automatically. • If the failure message is repeated on the next test: <ul style="list-style-type: none"> ○ Discontinue use of the <i>bibag</i> system. ○ Insert the blue bicarbonate connector into an appropriate liquid bicarbonate source in order to continue the treatment. ○ Alert a qualified service technician.
bibag: Post Rinse	The machine is rinsing the hydraulics after emptying the bag.	Advisory	Advisory only. No action is required.
bibag: Press Calib Err	<i>bibag</i> system pressure calibration error.	Advisory	Turn machine power off and back on. If the alarm is not cleared, take the machine out of service and alert a qualified service technician.
bibag: Press Sensor Err	The <i>bibag</i> connector pressure sensor is experiencing an error. The machine is in bypass mode.	Water Alarm	Open the <i>bibag</i> door, wait 30 seconds to relieve the pressure, and remove the bag. Place the bag back on the connector and close the door. If the alarm is not cleared, return the blood to the patient if alarm occurs during treatment. Take the machine out of service and alert a qualified service technician.
bibag: Press Too High	The pressure inside the <i>bibag</i> disposable is above the set alarm limits. The machine is in bypass mode.	Water Alarm	<p>Open the <i>bibag</i> door, wait 30 seconds to relieve the pressure, and remove the bag. Place the bag back on the connector and close the door.</p> <p>If the alarm is not cleared:</p> <ul style="list-style-type: none"> • Discontinue use of the <i>bibag</i> system. • Insert the blue bicarbonate connector into an appropriate liquid bicarbonate source in order to continue the treatment. • Alert a qualified service technician.

Message	Purpose of Message	Type	Action Required
bibag: Press Too Low	The pressure inside the <i>bi</i> bag disposable is below the set alarm limits. The machine is in bypass mode.	Water Alarm	Open the <i>bi</i> bag door, wait 30 seconds to relieve the pressure, and remove the bag. Place the bag back on the connector and close the door. If the alarm is not cleared: <ul style="list-style-type: none"> • Discontinue use of the <i>bi</i>bag system. • Insert the blue bicarbonate connector into an appropriate liquid bicarbonate source in order to continue the treatment. • Alert a qualified service technician.
bibag: Select Conc 45x	The operator has attempted to start dialysis using the <i>bi</i> bag system and an acid concentrate other than 45x is selected in Service Mode. Or The blue bicarbonate connector was not inserted into a liquid bicarbonate source if liquid bicarbonate dialysis is desired.	Advisory	<i>bi</i> bag dialysis is compatible only with 45x acid concentrates. Either, Restart the machine and enter Service Mode and select a 45x acid concentrate before beginning dialysis; Or Use liquid bicarbonate for dialysis by inserting the blue bicarbonate connector into an appropriate liquid bicarbonate source.
bibag: Temp Calib Err	Electronic self-test: temperature calibration error.	Alarm	Turn machine power off and back on. If the alarm is not cleared, take the machine out of service and alert a qualified service technician.
bibag: Temp Sensor Err	The <i>bi</i> bag temperature sensor is not reading the correct temperature.	Advisory	Insert the blue bicarbonate connector into an appropriate liquid bicarbonate source Or To use the <i>bi</i> bag disposable: If during treatment, rinse back the patient's blood and disconnect the patient from the machine. Run a Rinse program until message is cleared.
bibag: Val Comm Err	The <i>bi</i> bag interface board was unable to communicate with the actuator board.	Water Alarm	Turn machine power off and back on. If the alarm is not cleared, return the blood to the patient if alarm occurs during treatment. Take the machine out of service and alert a qualified service technician.
bibag: Valve 1 Err	Electronic self-test failure.	Water Alarm	Turn machine power off and back on. If the alarm is not cleared, return the blood to the patient if alarm occurs during treatment. Take the machine out of service and alert a qualified service technician.
bibag: Valve 2 Err	Electronic self-test failure.	Water Alarm	Turn machine power off and back on. If the alarm is not cleared, return the blood to the patient if alarm occurs during treatment. Take the machine out of service and alert a qualified service technician.

Message	Purpose of Message	Type	Action Required
bibag: Vent Too Long	The <i>bibag</i> system has been venting longer than ten minutes. The machine is in bypass mode.	Water Alarm	Press the RESET key to clear the message. Pull the blue bicarbonate connector out of its port and then firmly plug it back in. If the message persists, rinse back the patient's blood and disconnect the patient from the machine. Take the machine out of service, and alert a qualified service technician.
Bicarb Cond 2 High	Bicarbonate conductivity cell is measuring high dialysate bicarbonate conductivity when using the <i>bibag</i> system. The machine is in bypass mode.	Water Alarm	A single occurrence is not a problem if the machine automatically resets. If the problem lasts longer than five minutes or occurs repeatedly, turn power off and back on. If alarm is not cleared, return the blood to the patient if alarm occurs during treatment. Take the machine out of service. Alert a qualified service technician.
Bicarb Cond 2 Low	Bicarbonate conductivity cell is measuring low dialysate bicarbonate conductivity when using the <i>bibag</i> system. The machine is in bypass mode.	Water Alarm	A single occurrence is not a problem if the machine automatically resets. If the problem lasts longer than five minutes or occurs repeatedly, turn power off and back on. If alarm is not cleared, return the blood to the patient if alarm occurs during treatment. Take the machine out of service. Alert a qualified service technician.
Bicarb Cond. Cell Uncalibrated	Bicarbonate cell #117 not calibrated.	Alarm	Turn machine power off and back on. If alarm is not cleared, take the machine out of service and alert a qualified service technician.
Bicarb: Cond High	The actual or measured sodium bicarbonate concentrate conductivity has exceeded the high conductivity alarm limit when using the blue bicarbonate connector for liquid bicarbonate. The machine is in bypass mode.	Water Alarm	Wait five minutes for conductivity to stabilize. If the appropriate conductivity cannot be reached, make sure that the correct bicarbonate source is connected. If the alarm is still not cleared, rinse back the patient's blood, and disconnect the patient from the machine. Take the machine out of service, and alert a qualified service technician.

Message	Purpose of Message	Type	Action Required
Bicarb: Cond Low	The actual or measured sodium bicarbonate concentrate conductivity is below the low conductivity alarm limit when using the blue bicarbonate connector for liquid bicarbonate. The machine is in bypass mode.	Water Alarm	<p>Make certain the correct bicarbonate is connected to the machine and that there is enough concentrate available. Wait five minutes for conductivity to stabilize. If the appropriate conductivity cannot be reached:</p> <ol style="list-style-type: none"> 1. Plug the blue bicarbonate connector into its port. 2. Wait one minute and then re-connect the bicarbonate connector to the liquid bicarbonate source. 3. Wait five minutes for conductivity to stabilize. <p>If the conductivity alarm persists,</p> <ol style="list-style-type: none"> 1. Turn off the dialysate flow by selecting and confirming the Dialysate Flow on/off toggle-button on the "Dialysate" screen. 2. Disconnect the concentrate suction connectors from their wands. 3. Check for clogged filter screens in the connector handles, especially the blue bicarbonate connector. Clean if necessary with purified water. Verify that the connectors and filter assemblies are tightly screwed together with no air leak. 4. Insert the connectors back into the jugs and turn the dialysate flow back on by selecting and confirming the Dialysate Flow on/off toggle-button on the "Dialysate" screen. <p>If the conductivity alarm still cannot be cleared, discontinue treatment, rinse back the patient's blood and disconnect the patient from the machine. Perform an acid cleaning followed by a complete rinse cycle. Test machine operation. If conductivity alarm persists, take the machine out of service and alert a qualified service technician.</p>
Bicarb Press Calib Err	Bicarbonate pressure calibration error. The machine is in bypass mode.	Alarm	Turn machine power off and back on. If alarm is not cleared, return the blood to the patient if alarm occurs during treatment. Take the machine out of service and alert a qualified service technician.
Bicarb: Temp Calib Err	Bicarbonate temperature calibration error. The machine is in bypass mode.	Alarm	Turn machine power off and back on. If alarm is not cleared, return the blood to the patient if alarm occurs during treatment. Take the machine out of service and alert a qualified service technician.
Bicarb: Vent Too Long	The <i>bi</i> bag system has been venting longer than ten minutes when using the blue bicarbonate connector for liquid bicarbonate. The machine is in bypass mode.	Water Alarm	Press the RESET key to clear the message. If the alarm persists, turn machine power off and back on. If alarm is not cleared, return the blood to the patient if alarm occurs during treatment. Take the machine out of service and alert a qualified service technician.

Message	Purpose of Message	Type	Action Required
Blood Sensed	The operator has selected the Empty bibag button when blood is sensed. The bag cannot be emptied using the Empty bibag button when blood is sensed.	Warning	If the treatment is not yet finished and the bag must be changed, lift up on the <i>bi</i> bag door, wait 30 seconds to relieve the pressure, and remove the bag. Put a new bag on the connector and close the door again to continue using the <i>bi</i> bag system for the treatment.
Conductivity Limits set to default	The operator has entered a new concentrate in Service Mode, restarted the machine, changed the default concentrate values, and restarted the machine. The last entered concentrate has been set to the default conductivity limits.	Opening Screen Message	On the “Dialysate” screen, select the prescribed concentrate, enter the prescribed Base Na+ and Bicarbonate values for the patient and press the CONFIRM key to save the new values.
Must Calibrate To Run	Electronic self-test failure.	Alarm	Turn machine power off and back on. If alarm is not cleared, take the machine out of service and alert a qualified service technician.
RO Water Cond High	The Reverse Osmosis (RO) water inlet conductivity is too high.	Opening Screen Message	Press the RESET key to clear the message. Perform a Rinse cycle. If alarm is not cleared, take the machine out of service and alert a qualified service technician.
Tx Clock On	The operator has selected the Empty bibag button when the Tx Clock is running. The bag cannot be emptied using the Empty bibag button when the Tx Clock is running.	Dialog Message	If the treatment is not yet finished and the bag must be changed, lift up on the <i>bi</i> bag door, wait 30 seconds to relieve the pressure, and remove the bag. Put a new bag on the connector and close the door again to continue using the <i>bi</i> bag system for the treatment.
V104 Stuck Open	Bicarbonate concentrate port valve error. The machine is in bypass mode.	Water Alarm	Turn machine power off and back on. If alarm is not cleared, return the blood to the patient if alarm occurs during treatment. Take the machine out of service and alert a qualified service technician.
V104/108 Stuck Closed	Bicarbonate concentrate port valve error or rinse port valve error. The machine is in bypass mode.	Water Alarm	<p>Check for a kinked bicarbonate concentrate supply line.</p> <p>Make sure that the bicarbonate concentrate connector is firmly connected. If the bicarbonate concentrate source is a central feed system, make sure that the line is open.</p> <p>If the error occurs during a rinse, open the <i>bi</i>bag door for at least five seconds (with no <i>bi</i>bag attached). Rerun the rinse program.</p> <p>If alarm is not cleared, turn machine power off and back on. If alarm is still not cleared, return the blood to the patient if alarm occurs during treatment. Take the machine out of service and alert a qualified service technician.</p> <p> Note: If this error occurs upon power up or after any of the cleaning/disinfecting programs, make sure the blue bicarbonate connector is firmly plugged into the bicarbonate port then run the cleaning/disinfecting program again. If the alarm is not cleared, turn the machine off and back on and run a Rinse program. If the alarm is still not cleared, take the machine out of service and alert a qualified service technician.</p>

Message	Purpose of Message	Type	Action Required
V105 Stuck Open	Acid concentrate port valve error. The machine is in bypass mode.	Water Alarm	Turn machine power off and back on. If alarm is not cleared, return the blood to the patient if alarm occurs during treatment. Take the machine out of service and alert a qualified service technician.
V105 Stuck Closed	The acid concentrate supply line is not pulling in acid concentrate. The machine is in bypass mode.	Water Alarm	Check for a kinked acid concentrate supply line. Make sure that the acid concentrate connector is firmly connected. If the acid concentrate source is a central feed system, make sure that the line is open. If alarm is not cleared, turn machine power off and back on. If alarm is still not cleared, return the blood to the patient if alarm occurs during treatment. Take the machine out of service and alert a qualified service technician.
			 Note: If this error occurs upon power up or after any of the cleaning/disinfecting programs, make sure the red acid connector is firmly plugged into the acid port then run the cleaning/disinfecting program again.
Valve 104 Err	Bicarbonate concentrate port valve error. The machine is in bypass mode.	Water Alarm	Turn machine power off and back on. If alarm is not cleared, return the blood to the patient if alarm occurs during treatment. Take the machine out of service and alert a qualified service technician.
Valve 105 Err	Acid concentrate port valve error. The machine is in bypass mode.	Water Alarm	Turn machine power off and back on. If alarm is not cleared, return the blood to the patient if alarm occurs during treatment. Take the machine out of service and alert a qualified service technician.

2008T Machine with bibag System Specifications

Monitoring Dialysate
Conductivity

Average Accuracy: $\pm 1.5\%$

Method: Temperature compensated electronic conductivity meter with adjustable alarm limits.

bibag Dry Bicarbonate

Temperature compensated conductivity display with automatically set alarm windows ± 0.5 mS/cm around calculated conductivity, limited to ± 0.4 mEq/L @ 24 mEq/L bicarbonate or less.

With alarm window set at ± 0.5 mS/cm:

User can move alarm window up or down an additional:

± 0.2 mS/cm @ 40 mEq/L

± 0.1 mS/cm @ 35 mEq/L

no adjustment @ 29 mEq/L

Conductivity is based on the concentrates' compositional data entered in the Dialysate screen at the standard temperature of 25 °C.